

ANALOG DIALOGUE

A JOURNAL FOR THE EXCHANGE OF ANALOG TECHNOLOGY

VOLUME 3 ■ NUMBER 1 ■ Published by Analog Devices, Inc. ■ Cambridge ■ Massachusetts 02142 ■ MARCH 1969

Noise and Operational Amplifier Circuits

BY LEWIS SMITH,
D.H. SHEINGOLD

Editor's Note:

If we want to preamplify a small signal or measure a somewhat larger signal precisely, one of the limitations we encounter is noise. Most available treatments of noise are either highly mathematical or not readily applicable to operational amplifier circuits in a clearcut and obvious way. This article, it is hoped, will help cut through some of the confusion, and give the circuit designer a few basic principles, largely capable of immediate application to his problems, with useful results. If, after reading this article, you have any comments or questions, either on our treatment, or in relation to specific application problems, please let us hear from you.

INTRODUCTION

An operational amplifier's output always contains signals that could not have been predicted from the inputs and an accurately-known closed-loop transfer function, taking into account all impedance loads, known or unknown. These unwanted signals are called *noise*. Noise can be introduced into a circuit by the amplifier itself, by the components used in its feedback loop, and by the power supply; or it can be coupled or induced into the input, the output, the ground return, or the measurement circuit, from nearby – or in some cases, quite distant – sources.

The degree of the designer's interest in noise depends, of course, on (1) the desired resolution of the circuit in the band of interest, and (2) the avoidance of transmitting noise in frequency bands that are *not* of immediate interest. As operational amplifiers are used more extensively as preamplifiers and high-accuracy signal processors, resolution in operational amplifier circuits becomes of increasingly broad interest.

Recognizing the folly and futility of attempting to deal too comprehensively or rigorously with the complete range of noise phenomena, the present essay will attempt to provide tools for practical understanding, characterization, computation, and reduction of noise in the immediate environs of the amplifier. Coupled and induced noise in ground leads, output leads, etc., will be dealt with somewhat cavalierly by sug-

gesting simply that attention be paid to shielding, lead dress, and ground circuit design – all of which belong in the realms of system design and "good circuit practice."¹

From the standpoint of noise, the operational amplifier is uniquely qualified to serve in low-level and high-accuracy circuitry because

1. The amplifier transfer function may be chosen to pass only those frequency bands of interest.
2. The specific amplifier chosen for the job may be picked from among a wide range of types having differing noise characteristics, in order to obtain the most nearly ideal characteristics in the band of interest.
3. If the sources of noise are known and properly evaluated, the noise behavior of a wide range of amplifier circuits can usually be predicted to sufficient accuracy to permit a particular design to be done "on paper", with good probability of successful verification.

IN THIS ISSUE

	PAGE
<i>Noise and Operational Amplifier Circuits</i>	1
<i>Editor's Notes</i>	2
<i>Have You Seen . . . ? Log Circuit Article</i>	2
<i>Company Notes</i>	3
<i>Solid-State Electrometers: Low Bias, Low-Cost</i>	3
<i>Application Notes</i>	4
<i>In the Next Issue</i>	9
<i>General-Purpose Operational Amplifiers, Low-Cost</i>	15
<i>New Analog Devices' Catalog</i>	16
<i>Bibliography on Noise</i>	16

THE BASIC MODEL – VOLTAGE NOISE AND CURRENT NOISE (Figure 1)

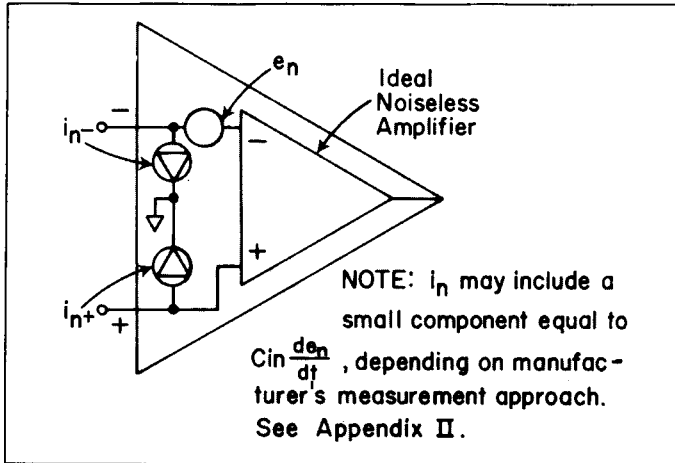

Figure 1. Voltage and Current Noise Model

A differential operational amplifier may be considered to be an ideal, noiseless amplifier, with noise current sources between each input terminal and common, and a noise voltage source effectively in series with one or the other input terminal. This model is quite similar to the E_{OS} - I_{bias} model used for offsets², which should not be surprising, because E_{OS} and I_{bias} can be considered as DC noise sources, modulatable by time, temperature, etc. For most practical purposes, noise voltage and noise current sources can be considered to be independent of one another. Ignoring the circuit and amplifier dynamics, for the moment, it is evident that, as with E_{OS} and I_{bias} , the instantaneous voltage component of noise could be measured (Fig. 2) in a low-impedance circuit with high gain, and the instantaneous current component could be measured with a very large (ideally “noiseless”) resistor. If there were no interaction between e_n and i_n , the output in the noise voltage measurement would be proportional to $(1 + R_2/R_1)$, and the output in the noise current measurement would be proportional to R_2 alone.

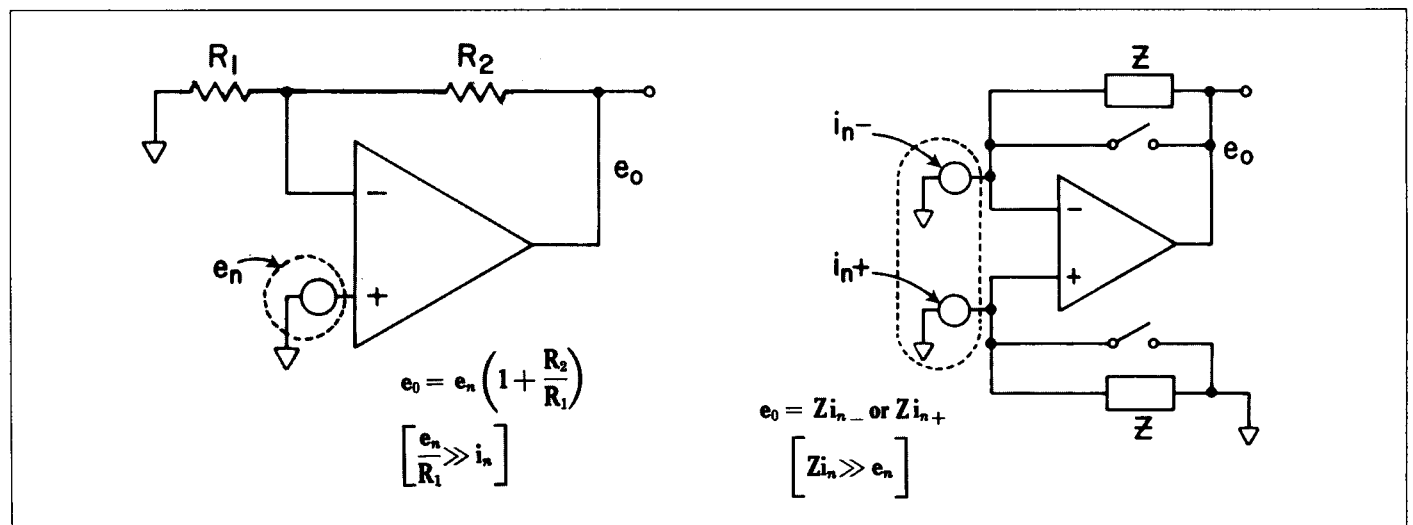

Figure 2. Rudimentary Measurement of e_n and i_n (Filters are used for narrow-band and spot noise measurements)

Note that the *instantaneous* sum of the two types of noise, appearing at the amplifier output, is

$$(1) \quad e_0 = \left(1 + \frac{R_2}{R_1}\right) e_n + R_2 i_n$$

and that the relative noise contributions of e_n and i_n are equal if

$$(2) \quad \frac{e_n}{i_n} = \frac{R_2}{1 + \frac{R_2}{R_1}}$$

that is, if the parallel combination of R_2 and R_1 is equal to the ratio of e_n to i_n . At impedance levels above e_n/i_n , current noise is dominant. The ratio of the RMS values of e_n and i_n is sometimes known as the “characteristic noise resistance” of the amplifier, in a given bandwidth, and it is a useful figure of merit for choosing an amplifier to match a given impedance level, or vice versa.

Noise coupled from *external sources* to the amplifier inputs can be considered as an additive voltage signal if the voltages and impedances are known, or as an additive current signal if its presence is determined by measurement at the amplifier site. This is shown compactly in Figure 3.

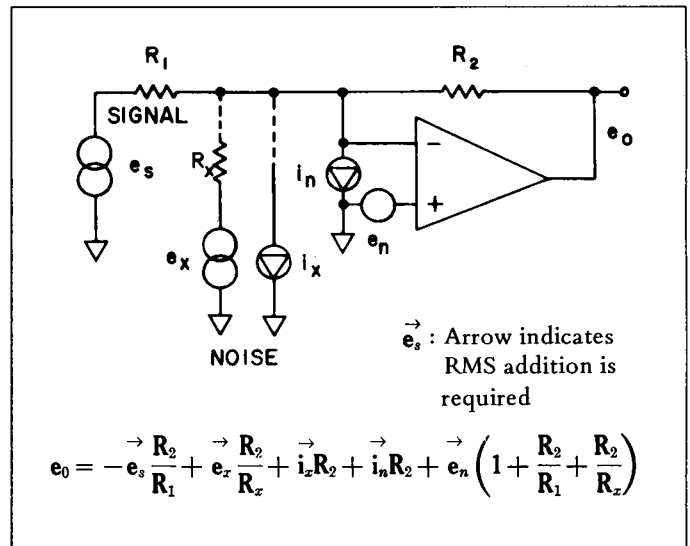

Figure 3. Contributions of Internal and External Noise Sources

NOISE GAIN AND SIGNAL GAIN

Figure 4 shows the basic feedback model of an inverting amplifier with a number of resistive inputs. For large values of loop gain ($A\beta$), the noise gain for voltage noise is essentially $1/\beta$. If $A\beta$ is not much greater than unity, one should use the more exact expression

$$(3) \quad e_0 = \frac{1}{\beta} \left[\frac{1}{1 + \frac{1}{A\beta}} \right] e_n$$

The comparable current noise expression is

$$(4) \quad e_0 = i_n Z_f \left[\frac{1}{1 + \frac{1}{A\beta}} \right]$$

It should be noted that, for passive feedback elements, $1/\beta$ is never less than unity, and it also is larger than the closed-loop gain for any of the input signals. Therefore the total spectrum of e_n will appear at the output, with *at least* unity gain, despite less-than-unity signal gains, or narrow signal bandwidths. It should also be noted that, in the general case where A and β are both dynamic expressions, if the loop gain has substantially more than 90° phase shift, and the amplifier is in consequence lightly-damped in the vicinity of the frequency at which $A\beta = 1$, the noise gain at that frequency may peak at substantially greater than unity, *even if the signal gain rolls off smoothly at a very much lower frequency*. See Fig. 5 for a flagrant, easy-to-understand example.

COMBINING NOISE SIGNALS

This topic will be dealt with in some depth shortly. However, it is desirable to bear in mind the basic notion that RMS values of signal or noise voltage or current from essentially uncorrelated sources (for example, noise from different sources, or noise from different portions of the frequency spectrum of a given source) are combined by computing the square root of the sum of the squares. It should be evident that larger quantities will be emphasized and smaller quantities suppressed. For example, if $X = 3Y$ the error incurred by simply ignoring Y is only about 5%. ($\sqrt{1^2 + 3^2} = \sqrt{10} \cong 3.16 \cong 3.0 \times 1.05$).

TO THE READER: The sections that follow are necessary in order to construct a coherent approach to a technique for predicting the "total RMS noise" of an operational amplifier circuit quickly and easily. The material is not the easiest of reading, and it covers a wide range of topics, the exact place of which in the final scheme may be somewhat difficult to second-guess. Nevertheless, it is a necessary part of the background, and, if read with patient attention, may prove interesting and informative. If you would like to get an idea of the resulting technique, look ahead to page 10.

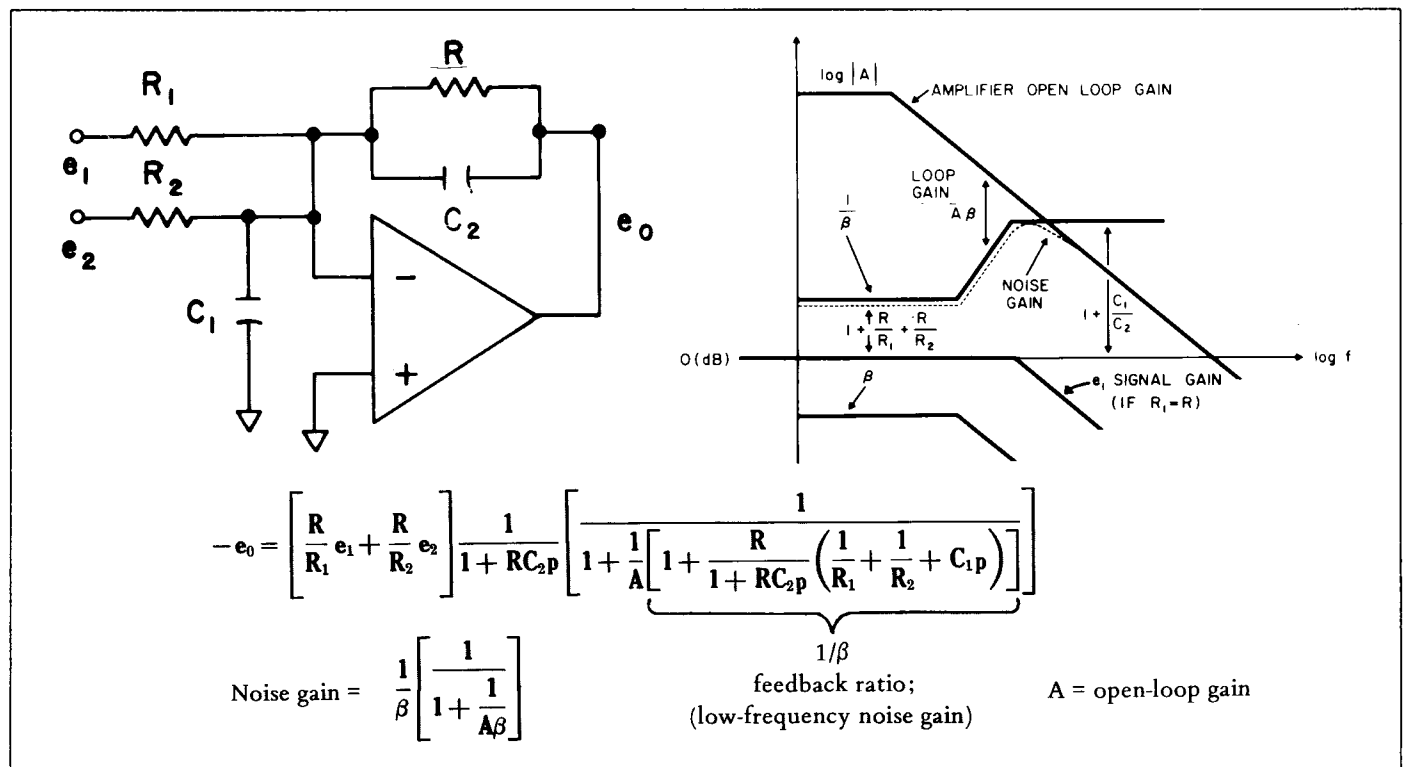

Figure 4. Feedback Circuit Relationships

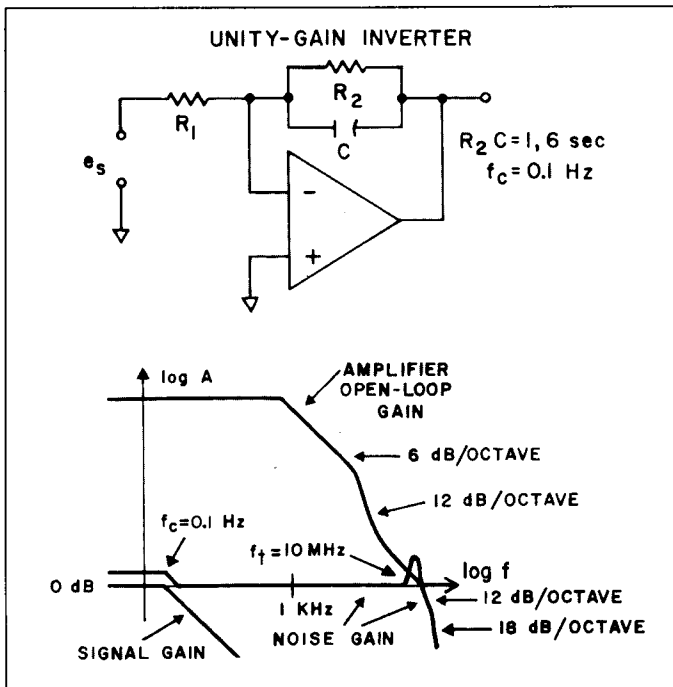

Figure 5. Noise Bandwidth vs. Signal Bandwidth

HOW NOISE IS CHARACTERIZED

Periodically-recurring noise may be described in terms of repetition rate, waveform, and magnitude (e.g., chopper noise.) Irregularly-recurring noise may be described in terms of its waveshape and magnitude only, since the repetition is not regular (to some extent, popcorn noise). Aperiodic noise not having a recurring waveshape (and this includes all the types of random noise to be described below) is usually dealt with in terms of some of its statistical properties: RMS value, peak value, and frequency content.

RMS Value. It is a characteristic of most kinds of random noise that if the averaging interval is made sufficiently long, the RMS value obtained is substantially repeatable. Therefore, RMS value in the bandwidth of interest, averaged over a sufficiently long interval, is a useful and meaningful way of characterizing such random noise. It is by far the most convenient for correlating noise numbers between vendors and users. The definition of RMS value of voltage is given by

$$(5) \quad E_{rms} = \sqrt{\frac{1}{T} \int_0^T e^2 dt}$$

where

- E_{rms} = RMS voltage value
- T = Interval of observation
- e = Instantaneous noise voltage

Substituting the instantaneous value of current, i , gives I_{rms} the RMS current value. When performing RMS measurement, either a "true RMS" meter must be used, or the reading of an AC average (sine wave "RMS"-calibrated meter) should be multiplied by a factor of 1.13.

Peak Values. Noise may also be characterized in terms of the difference between the largest positive and negative peak excursions observed during an arbitrary interval. For some applications, in which peak-to-peak noise may limit system performance, peak-to-peak measurement may be essential. Nevertheless, because noise is for all practical purposes Gaussian in amplitude distribution, and hence the highest noise amplitudes have the smallest (yet non-zero) probability, peak-to-peak noise is difficult to measure repeatably. Because RMS values are so easy to measure repeatably, and are the most usual form for presenting noise data non-controversially, the table below should be useful for estimating the probabilities of exceeding various peak values, given the RMS values.

Nominal "peak-to-peak"	Percentage of time that noise will exceed nominal "peak-to-peak" value
2.0 x RMS	32%
3.0 x RMS	13%
4.0 x RMS	4.6%
5.0 x RMS	1.2%
6.0 x RMS	0.27%
6.6 x RMS	0.10%
7.0 x RMS	0.046%
8.0 x RMS	0.006%

Peak-to-peak vs. RMS (Gaussian distribution)

The casually-observed peak-to-peak noise varies between 3 x RMS and 8 x RMS, depending on the patience of, and amount of data presented to, the observer. Oscilloscope traces should be observed at high intensity, because considerable averaging occurs at low intensity, which will produce apparent results closer to the RMS value. Peak amplitude distribution analyzers are becoming available, for automating these measurements.

INTERFERENCE NOISE VS. INHERENT NOISE

There are two basic classifications of noise for a given circuit; they are *interference noise*, which is noise picked up from outside the circuit, and *inherent noise*, which is noise arising within the circuit itself.

Interference noise may be periodic, irregularly recurring, or essentially random, and it ordinarily may be reduced substantially (or forestalled) by taking precautions to minimize electrostatic and electromagnetic pickup from power sources at line frequencies and their harmonics, radio broadcast stations, arcing of mechanical switches, and current or voltage spikes resulting from switching in reactive circuits. Such precautions may include filtering, decoupling, electrostatic and electromagnetic shielding of leads and components, use of guarding potentials, elimination of ground loops, physical reorientation of leads and components, use of damping diodes across relay coils, choice of low circuit impedances where possible, and choice of power and reference supplies having low noise. Interference noise resulting from vibration may be reduced by proper mechanical design. A table outlining some of the sources of interference noise, their typical magnitudes, and ways of dealing with them is shown in Figure 6.

External Source	Typical Magnitude	Typical Cure
60Hz power	100pA	Shielding, attention to ground loops, isolated power supply
120 Hz supply ripple	3μV	Supply filtering
180Hz magnetic pick-up from saturated 60Hz transformers	0.5μV	Reorientation of components
Radio broadcast stations	1mV	Shielding
Switch-arcing	1mV	Filtering of 5 to 100MHz components, attention to ground loops and shielding
Vibration	10pA (10 to 100Hz)	Proper attention to mechanical coupling; elimination of leads carrying large voltages near input terminals (Note: $i = \frac{d(Cv)}{dt} = C \frac{dv}{dt} + v \frac{dC}{dt}$)
Cable vibration	100pA	Use low noise (carbon-coated dielectric?) cable
Circuit boards	0.01 to 10 pA/ $\sqrt{\text{cps}}$ below 10Hz	Clean boards thoroughly, use teflon insulation where needed, and guard well

Figure 6. Typical Sources of Interference Noise

But even if all interference noise is removed, *inherent noise* will still be present. Inherent noise is usually random in nature, most often arising in resistances and semiconductor elements, such as transistors and diodes. (An example of a *non-random* inherent noise component is chopper noise in chopper-stabilized amplifiers.) Random noise arising within resistances is known as *Johnson noise*, (or thermal noise). Random noise arising within semiconductor elements may be one of the following three types: *Schottky* (or shot) noise, *flicker noise* (1/f noise), and *popcorn noise*.

COMMON FORMS OF RANDOM NOISE

Johnson noise. Thermal agitation of electrons in the resistive portions of impedances results in the random movement of charge through those resistances, causing a voltage to appear corresponding to the instantaneous rate of change of charge (i.e., current) multiplied by the appropriate resistance. Ideally-pure reactances are free from Johnson noise.

The Johnson noise voltage within a bandwidth B generated by thermal agitation in a resistance is given by

$$(6) \quad E_{rms} = \sqrt{4kTRB}$$

where

- k = Boltzmann's constant = 1.374×10^{-23} Joules/° Kelvin
- T = Absolute temperature (degrees Kelvin)
- R = Resistance (ohms)
- B = Bandwidth (cycles per second)

At room temperature, with more convenient units, this expression becomes

$$(7) \quad E_n = 0.13 \sqrt{R \times B} \cong \frac{1}{8} \sqrt{R \times B} \text{ microvolts}$$

where

- R = Resistance (megohms)
- B = Bandwidth (cycles per second)

Johnson noise is quite often expressed as an equivalent current

$$(8) \quad I_n = \frac{E_n}{R} = 0.13 \sqrt{\frac{B}{R}} \cong \frac{1}{8} \sqrt{\frac{B}{R}} \text{ picoamperes}$$

Ordinarily, Johnson noise is a less important source of noise *within the amplifier* than the noise produced within semiconductors; however it is the primary source of noise contributed by the signal source and the feedback circuitry, where resistance values are apt to be higher. In some situations, the Johnson noises of the components in the external circuit are completely dominant. For example, if the source resistance in a particular application is to be 10 megohms, there is little point to selecting an amplifier with *low voltage noise*, since the Johnson noise from the 10 megohm resistor will be the chief source of noise at the output, unless the amplifier's input *current noise* is high. In this example, the resistor noise in a 1kcps bandwidth would be 13 microvolts RMS, corresponding to current noise of 1.3 picoamperes.

Schottky noise. Shot noise arises whenever current is passed through a transistor junction. The noise is normally expressed as a current, which will, of course pro-

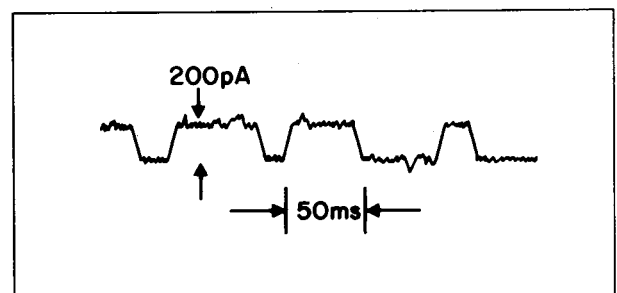

Figure 7. Typical "Popcorn" Noise

duce voltage drops in impedance, such as transistor emitter resistance. A convenient equation for shot noise is

$$(9) \quad I_n = 5.7 \times 10^{-4} \sqrt{IB} \text{ picoamperes}$$

where

I = junction current in picoamperes

B = bandwidth of interest in cps

In a typical operational amplifier circuit using bipolar input transistors, the input transistor base current, flowing through the base-emitter junction, produces a Schottky noise component, which is a part of the amplifier's equivalent noise current source. Other P-N-junction-generated noise currents (internal to the operational amplifier), when divided by appropriate transconductances, will create an equivalent noise voltage at the input.

Flicker noise (1/f noise.) In the frequency range below 100Hz, most amplifiers exhibit another noise component that dominates over Johnson and Schottky components and becomes the chief source of error at these frequencies. Flicker noise is thought to be a result of imperfect surface conditions on transistors. Carbon composition resistors, if they carry much current, may contribute noise similar to flicker noise of transistors. (It is good engineering practice to use metal film or wirewound resistors wherever significant currents flow through the resistor and low noise at low frequencies is a definite requirement).

Flicker noise does not have an equal contribution at each frequency. The spectral noise density (to be defined below) of this type of noise typically exhibits a -3dB per octave slope.

Popcorn noise. Some transistors, especially those of integrated circuit monolithic construction (from some manufacturers), jitter erratically between two values of h_{fe} causing additional base current noise of the form shown in Fig. 7. The premium paid for most high-performance amplifier types includes tests to weed out units having transistors or IC's that exhibit this effect.

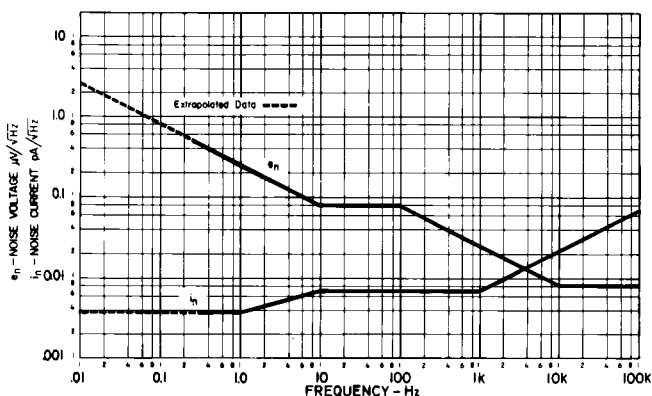

Figure 8. Noise Spectral Density. Analog Devices Model 144 (Economical FET Amplifier)

IN THE NEXT ISSUE

Settling Time. Based in part on a paper presented at NEREM 1968, this article will discuss the components of delay and error that contribute to the speed limitations of high-precision operational amplifier circuits, and their significance to the designer and tester of practical circuits. It will include a discussion of "glitch" phenomena in Digital-to-Analog Converter circuits. It will also present some surprising conclusions about the effects on settling time of deviation from 6 dB/octave slope in the open loop response of operational amplifiers employed in precision buffer circuits.

NOISE DENSITY SPECTRUM

Noise exists in all parts of the frequency spectrum, and the noise contribution of a resistor or amplifier varies with the range of frequency over which the observation is made. Probably the most useful manner of describing a noise characteristic is a spectral noise density plot, in which noise is shown as a function of frequency, usually on log-log axes.

Spectral noise density, e_n , at a given frequency f , is defined as the square root of the rate of change of mean-square voltage with frequency. Conversely, the RMS value in a given band is the square root of the definite integral of the square of spectral noise density over a given band of frequencies.

$$(10) \quad e_n^2 \equiv \frac{d}{df} (E_n)^2 \quad (11) \quad E_n = \sqrt{\int_{f_1}^{f_2} e_n^2 df}$$

Inasmuch as average power is proportional to E_n^2 , a simpler way of expressing this concept is: e_n^2 is proportional to the variation of noise power per cycle per second. Thus, e_n is expressed as the noise voltage per (square) root-cycle (per second).

From equation (11), we see that a lower and an upper frequency limit, f_1 and f_2 , are required, as well as a knowledge of the manner in which e_n varies with frequency, in order to evaluate the integral and calculate the actual RMS noise voltage. A typical spectral density plot (both e_n and i_n) for Analog Devices types 144 is shown in Figure 8.

COMMON DENSITY SPECTRUM CONFIGURATIONS

White noise. In a white noise spectrum, e_n is constant as a function of frequency. Thus, the RMS noise value as measured in a given bandwidth via an ideal sharp-cutoff filter would be

$$(12) \quad E_n = \sqrt{\int_{f_1}^{f_2} e_n^2 df} = e_n \sqrt{f_2 - f_1}$$

Because $f_2 - f_1$ defines a bandwidth (cf. B in equations 6,7,8 9), it is evident that both Johnson noise and Schottky noise are *white noise*, and that e_n , for Johnson noise, is $0.13\sqrt{R}$ microvolts per root cycle, or $0.13x\sqrt{1/R}$ picoamperes per root cycle (R given in megohms), and Schottky noise is $5.7 \times 10^{-4}\sqrt{I}$ picoamperes per root cycle (I also in picoamperes).

If f_1 is less than 10% of f_2 , a simple expression for all the white noise from f_2 down to "DC", with less than 5% error, is

$$(13) \quad E_n = e_n \sqrt{f_2}$$

Pink noise. A generic term applied to ideal $1/f$ noise, for which e_n is exactly proportional to $\sqrt{1/f}$, is *pink noise*. This may be expressed

$$(14) \quad e_n = K \sqrt{\frac{1}{f}}$$

K is the value of e_n at $f = 1$ Hertz

The RMS noise in the band between f_2 and f_1 may be computed by substituting equation (14) in equation (11)

$$(15) \quad E_n = K \sqrt{\int_{f_1}^{f_2} \frac{df}{f}} = K \sqrt{\ln \left(\frac{f_2}{f_1} \right)}$$

On a log-log plot of e_n vs. frequency, the slope will be -3dB per octave (e_n^2 vs. frequency would have a -6dB per octave slope). Because the RMS value of pink noise depends on the ratio of the frequencies defining the band of interest, every octave or decade of pink noise will have the same RMS noise content as every other octave or decade.

It is instructive to compute the RMS pink noise in the nine-decade realm below 1 Hz (10^{-9} Hz \cong 1 cycle per 30 years). If the RMS value of pink noise in the decade from 0.1 to 1 Hz is 1 microvolt, then the total RMS noise over all nine decades is $\sqrt{9 \times 1^2} = 3\mu\text{V}$.

This tells us that, as the lower frequency f_1 , goes to extremely small values ("DC"), RMS pink noise (and thus ideal flicker noise) will have less significance than drift caused by environmental factors, component aging, or perhaps even component life.

Spot noise. If we divide the spectrum of frequency into sufficiently narrow "spots" or intervals, $\Delta f_1, \Delta f_2, \Delta f_3$, etc., so that we may consider e_n (or its "average" value) essentially constant, then an incremental approximation may be used to evaluate the RMS noise, E_n , using equation (11). The RMS noise in the total interval to be computed is simply the root-sum-of-the-squares of the noise in the incremental intervals

$$(16) \quad E_n = \sqrt{e_{n_1}^2 \Delta f_1 + e_{n_2}^2 \Delta f_2 + \dots}$$

If the intervals are all equal $= \Delta f$, equation (16) becomes

$$(17) \quad E_n = \sqrt{\Delta f} \sqrt{e_{n_1}^2 + e_{n_2}^2 + \dots}$$

Filter skirt errors. Our discussion of frequency content has so far assumed that it is possible to combine noise source contributions, band by band, with perfect sharp-cutoff filters. In actual circuits, however, a quite common filter response is that of a single time constant (either lead or lag). Such a filter will have significant response in the band beyond its nominal cutoff frequency. For example, equation (13) for RMS white noise in the whole band below f_2 must be multiplied by 1.26 to account for the white noise passed at frequencies higher than f_2 by a first-order lag filter, having cutoff frequency f_2 . In effect, the "noise bandwidth" is $f_2\pi/2$ and, ignoring the noise passed in frequencies under the filter skirt (i.e., beyond the cutoff frequency) will result in a 26% error. However, it should be noted that errors due to ignoring the skirts of higher-order filters are considerably less. The RMS contribution of the 6dB per octave skirt alone is $0.76e_n\sqrt{f_c}$.

NOTE TO THE READER: Thank you for your patience. You have now arrived at the point of this necessarily lengthy discussion: a graphical technique for easily predicting the noise spectrum and the total noise of an operational amplifier circuit, using the spectral density plots for voltage and current noise, the closed-loop gain and impedance level of the feedback amplifier circuit, and certain approximations made understandable by the background material.

BRIEF REVIEW OF RELEVANT POINTS

1. Pink noise contributes equal increments of RMS noise over each octave or each decade of the spectrum. Each increment will be 1.52K per decade, or 0.83K per octave, where $K = e_n$ or i_n at 1 Hz.
2. Bandwidth for white noise is substantially equal to the higher frequency, if one is considering bandwidths greater than 1 decade.
3. Because of root-sum-of-the-squares addition, the greater of the RMS values of two uncorrelated noise signals will be substantially equal to their sum, if the greater is at least 3x the lesser (i.e., if 20 log-of-their-ratio is greater than 10dB).
4. Noise in different portions of a random spectrum typical of amplifier circuits is uncorrelated, and can hence be added by root-sum-of-the-squares.

THE "PINK NOISE TANGENT" PRINCIPLE

Consider Fig. 9, which shows an arbitrary plot of output noise spectrum on a log voltage vs. log frequency scale. It is a purely arbitrary choice, chosen simply as an example. Consider that it might have been arrived at by simple addition on a log scale (in effect obtaining the product) of e_n and an amplifier's closed loop gain (i.e., true noise gain).

First, let us compute the noise in each portion of the spectrum, using point (4)

Region	RMS Noise	Why
1	22 μ V	Pink noise, 2 decades, $\sqrt{2} \times 1.52 \times 10$
2	100 μ V	White noise, 2 decades, $10 \times \sqrt{100}$
3	152 μ V	Pink noise, 1 decade, $1.52 \times \sqrt{100}$
4	72 μ V	6dB/octave skirt, $0.76 \times 3 \times \sqrt{1000}$
5	42 μ V	White noise, $0.3 \times \sqrt{20,000}$
6	40 μ V	6dB/octave skirt, $0.76 \times 0.3 \times \sqrt{30,000}$

The RMS total of these noises is

$$\sqrt{152^2 + 100^2 + 72^2 + 42^2 + 40^2 + 22^2} = 205 \text{ microvolts}$$

Just as a matter of interest, it is worth noting that the root-square sum of those portions nearest to the point of tangency of the K = 100 pink noise characteristic is

$$\sqrt{152^2 + 100^2 + 72^2} = 196 \text{ microvolts}$$

Before making our point, let us look at the example of Fig. 10, which shows another response. The noise bookkeeping is as follows:

Region	RMS Noise	Why
1	8 μ V	Pink noise, 3 decades, $K=3.16\sqrt{3} \times 3.16 \times 1.52$
2	126 μ V	White noise and skirt (6dB/octave) $1.26 \times 1.0 \times \sqrt{10^4}$
3	45 μ V	White noise, $0.1 \times \sqrt{200,000}$
4	42 μ V	6dB/octave skirt, $0.76 \times 0.1 \times \sqrt{300,000}$

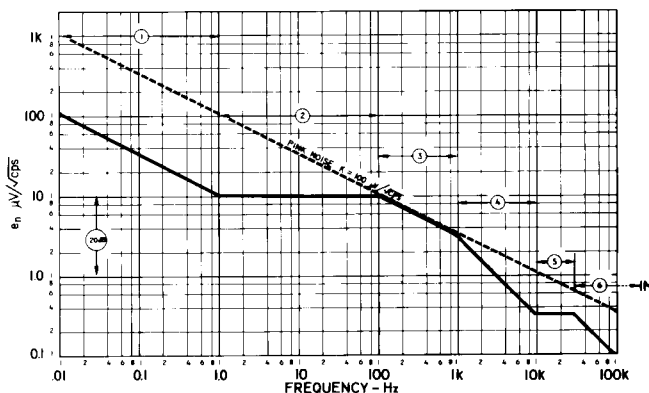

Figure 9.

The RMS total of these noises is

$$\sqrt{126^2 + 45^2 + 42^2 + 8^2} = 140 \text{ microvolts}$$

Note that there is less than 10% error by assuming that all the noise is in Region 2, and negligible error in omitting Region 1 entirely. Furthermore, if one makes the purely arbitrary assumption that *all* the noise present can be approximated by one decade of pink noise in the region of tangency (10kHz), it would amount to $1.52 \times 100 = 152$ microvolts, which is less than 10% error in the *conservative* direction.

The point is this: If a characteristic -3dB per octave pink noise slope is lowered until it is tangent to the noise output characteristic of the amplifier, the only significant contribution to total noise output will come from those portions of the amplifier noise characteristic in the immediate vicinity of that pink noise slope. Any portions of the amplifier noise characteristic that are substantially (i.e., typically more than 10dB) below the pink noise slope will contribute insignificantly. The explanation for this is that the pink noise slope is the locus of equal per-octave (or per decade) contributions to total noise. In the region of tangency, it will be seen, lies the maximum noise contribution of the amplifier circuit. The noise contributions in any other comparable interval must be less, and in intervals more than typically 10dB below the -3dB per octave slope, they will be insignificant.

A TYPICAL EXAMPLE

Consider the circuit of Fig. 11. It is a summing amplifier with gains of 10 and 100, using a 1 megohm feedback resistor, paralleled by 160pF. The amplifier's open loop DC gain is 100dB, and f_t is 1MHz.

COMPUTE NOISE GAIN

Figure 11 shows the amplifier's assumed open loop gain-frequency plot, and the attenuation of the feedback network ("noise gain"). The loop gain ($A\beta$) is the difference between the two curves. The attenuation of the feedback network can be shown to be a constant attenuation of x111 up to 1kHz, and a 6dB/octave rolloff down to unity (i.e., 0 dB).

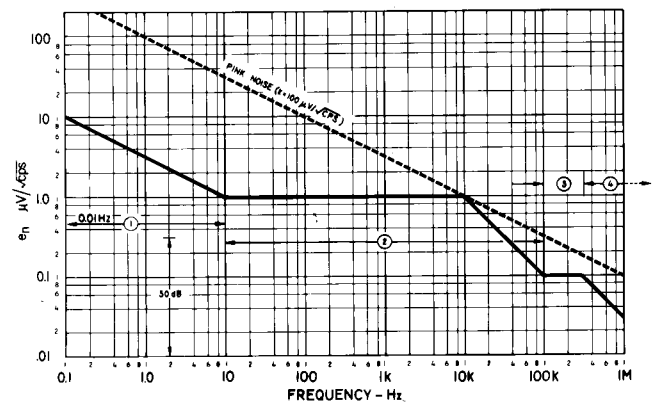

Figure 10.

First, the usual stability analysis is performed. In this case, it is pretty simple: The loop gain, $A\beta$, passes through a magnitude of unity with about 90° phase shift (90° from the amplifier, none from the feedback network) which implies not only stability, but absence of peaking as well. Thus the noise gain, after dropping to unity at about 100kHz, will resume its rolloff at about 1 MHz.

IDENTIFY AND COMPUTE CONTRIBUTIONS OF NOISE SOURCES

The sources of noise are: Amplifier e_n and i_n , and Johnson noise in the three resistors. Figure 12 shows (to begin with) a plot of i_n and e_n on a log-log scale. (Dashed and lower solid). We now plot the effective output noise contribution of all noise sources, in order to establish those that are most significant, the frequency bands in which they will appear, and to compute the total RMS "inherent" noise of the circuit, according to the method just described.

Amplifier voltage noise (e_n). At the output, the noise spectrum will consist of e_n , multiplied by the noise gain. Inasmuch as e_n and noise gain are both plotted on compatible log-log scales, we have simply to add the two spectra. (Upper solid line).

Amplifier current noise (i_n). At the output, the noise spectrum will consist of i_n , multiplied by the feedback impedance (1 megohm to 1 kHz, with a 6dB per octave rolloff thereafter.) This will consist simply of a curve paralleling the current curve at low frequencies, of magnitude $i_n R_f$, and departing from it at a 6dB per octave rate below the break frequency. (Coarse dotted line)

Resistor noise. It is illustrative to show the contribution of each resistor separately (since their noises, being uncorrelated, will be combined in RMS fashion). In the present example, it will be found convenient to treat each resistor as a noise current source. The current noise from each of the three resistors will be multiplied by the feedback impedance, in the same way as the amplifier's i_n . (dotted, starred, and light dashed lines)

Establish location of tangent pink noise line. Having plotted the spectral density of computed output noise from each of the five sources, a -3dB per octave slope is lowered until it

touches one of the curves. This will be seen to be the e_n (\times noise gain) curve, at 1 kHz. Qualitatively, we observe immediately the following:

The bulk of the random noise will occur in the vicinity of 1kHz, mostly contributed by the amplifier, but with some contribution from the 10k resistor.

There will be a minor additional contribution at 1 MHz.

If we (in a purely arbitrary manner) approximate all the noise by the decade of pink noise ($K = 160\mu\text{V}/\sqrt{\text{cps}}$) in the vicinity of 1kHz, the total RMS noise would be $1.52 \times 160 = 244$ microvolts. That this is quite conservative will be seen by the actual calculation, from the curves

COMPUTE THE TOTAL NOISE

Region	E_{rms}	Method
100kHz up (amplifier)	$76\mu\text{V}$	White noise -6dB/octave rolloff $1.26 \times 0.06 \times 10^3$
1kHz to 100kHz (amplifier)	$120\mu\text{V}$	White noise -6dB/octave skirt $0.76 \times 5 \times \sqrt{1000}$
200Hz to 1kHz (amplifier)	$116\mu\text{V}$	Spot noise, summation of 100cps spots $10\sqrt{\sum e_n^2}$
All frequencies (resistor)	$52\mu\text{V}$	10k resistor, white noise, 1kHz rolloff $1.26 \times 1.3 \times 1000$

The above constitute all the significant contributions, and add up, RMS fashion, to

$$\sqrt{76^2 + 120^2 + 116^2 + 52^2} = 190 \text{ microvolts RMS}$$

It may be a useful exercise for the reader to convince himself that all other sources and bands contribute in a minor or negligible degree.

FURTHER DISCUSSION OF THIS EXAMPLE

The total random noise of 190 microvolts may be referred back to either of the inputs to determine the signal-to-noise ratio. It will be seen that, referred to e_1 , (gain of 100) the noise is 1.9 microvolts RMS, and, referred to e_2 (gain of 10), the noise is 19 microvolts RMS.

The signal "cutoff" frequency of this circuit is 1kHz, and it will be seen that, because of the absence of peaking, the noise contribution at 1MHz, though significant, is a relatively small contributor to the total. However, if an amplifier having less phase margin were used, and if the signal bandwidth were also less, (larger feedback capacitor used) it can be seen that the dominant noise could be in the region of 1MHz, *even though this is well beyond the passband of interest*. If this is the case in a given application, and an amplifier having narrower bandwidth is not available, it may be desirable to follow the amplifier by a low-impedance low-pass R-C or L-C filter, to greatly reduce the high-frequency noise. If this is done, the post-filter transfer function is applied to the output noise spectrum, and the pink noise slope is lowered until it is once again tangent to one of the curves. An important suggestion to the circuit designer is: *Do not use an amplifier having greater bandwidth than is necessary for the application (if feasible).*

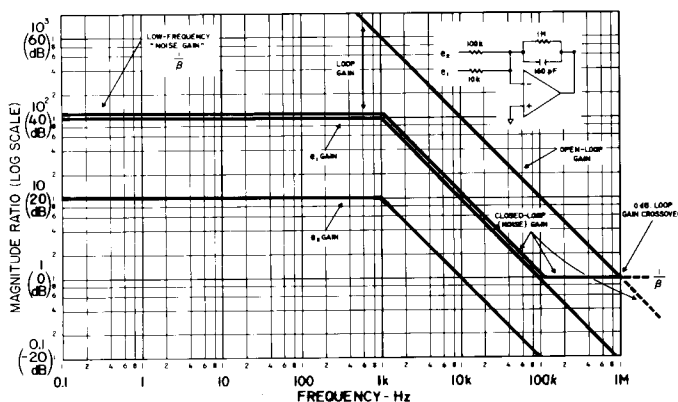

Figure 11. Closed-loop Gain Relationships

NOISE FIGURE

It will be noted that we have not yet discussed an amplifier's "noise figure." Noise figure is a measure of the additional noise contributed by the amplifier over-and-above that of the source resistance. It is often computed by the formula

$$(18) \quad N.F. = 10_{\log} \frac{E_n^2 + I_n^2 R_s^2 + 4kTR_s B}{4kTR_s B}$$

where R_s is the source resistance. Noise Figure is expressed in dB, and is zero for an ideal noiseless amplifier. For a given amplifier, N.F. is minimum if $R_s = E_n/I_n$, a quantity known as the "optimum noise resistance." It should be noted that N.F. depends on bandwidth, and that R_{optimum} may differ from frequency band to frequency band. A better way to express Noise Figure may be in terms of the actual closed-loop configuration, and the computed RMS noise. For the example given above, using this definition

$$\begin{aligned} N.F. &= 10_{\log} \frac{\text{(Total output noise)}}{\text{(Source resistor noise)}} \\ &= 10_{\log} \frac{(190)^2}{(1.26)^2 (1.3)^2 (1000)} = 11.3 \text{ dB} \end{aligned}$$

Note that, for this amplifier, R_{optimum} is

$$\frac{0.12 \mu\text{V}/\sqrt{\text{cps}}}{10 \text{ pA}/\sqrt{\text{cps}}} = 12 \text{ k}\Omega$$

in the low frequency band, and rises to

$$\frac{0.05 \mu\text{V}/\sqrt{\text{cps}}}{0.12 \text{ pA}/\sqrt{\text{cps}}} = 400 \text{ k}\Omega \text{ at } 1 \text{ kHz.}$$

Note also that the best noise figure does not always produce the lowest noise. This concept is perhaps of greatest usefulness when considering non-inverting amplifier configurations. When experimenting with various circuit impedance levels, it is good practice to add a small signal as a reference, in order to aid in maximizing signal-to-noise ratio, rather than merely minimizing output noise.

Footnotes:

¹See Noise Bibliography, page 16

²See *Operational Amplifiers*, part IV: "Offset and Drift in Operational Amplifiers," Analog Devices, Inc. 1966

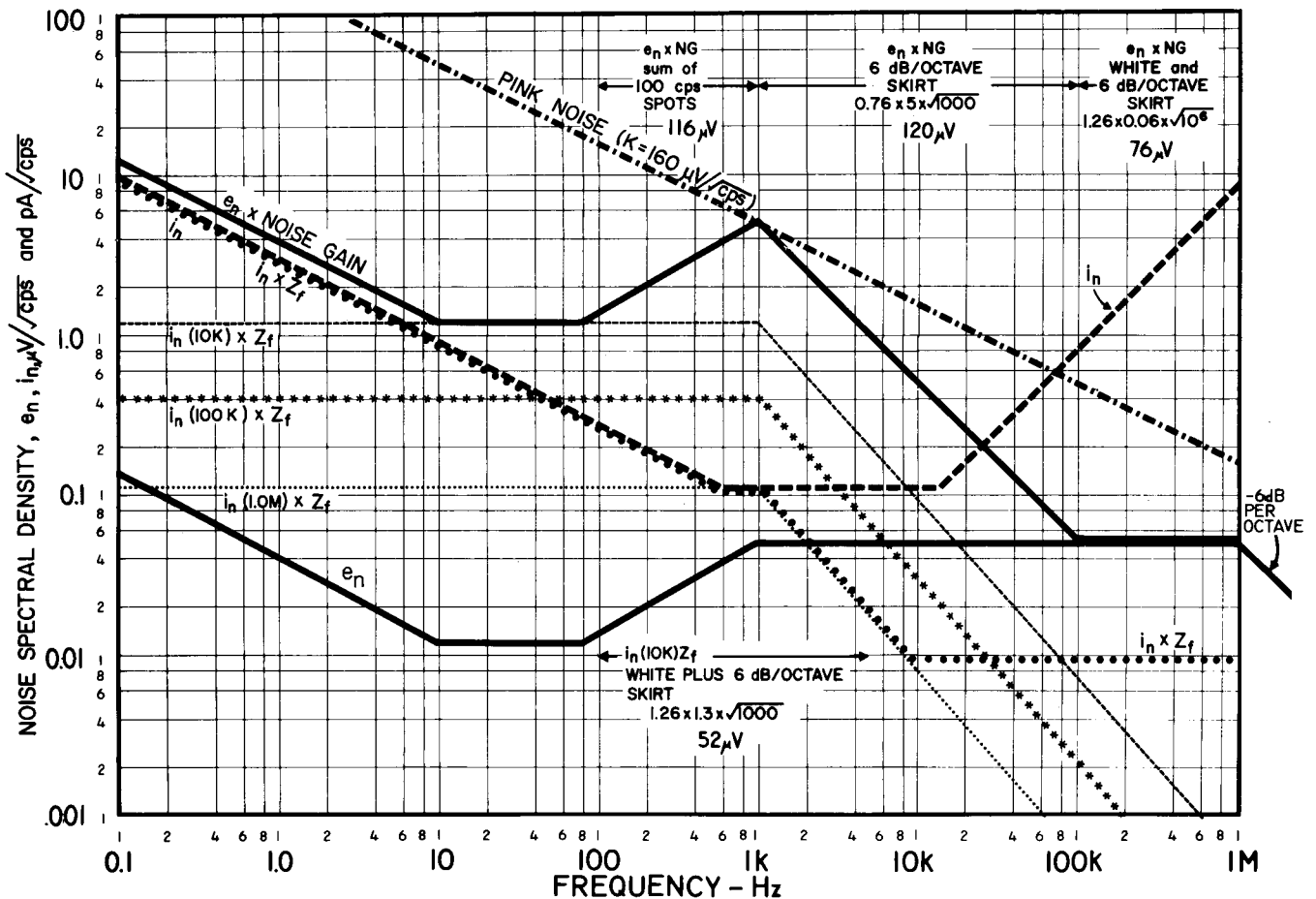

Figure 12. Closed-loop Noise Spectra

APPENDIX I

RANDOM NOISE DENSITY SPECTRA FOR TYPICAL ANALOG DEVICES' AMPLIFIER MODELS (see also Figure 8 for Model 144, an economy FET type). See data sheets for additional noise information on these types, including typical noise wave forms and RMS noise vs. source resistance plots

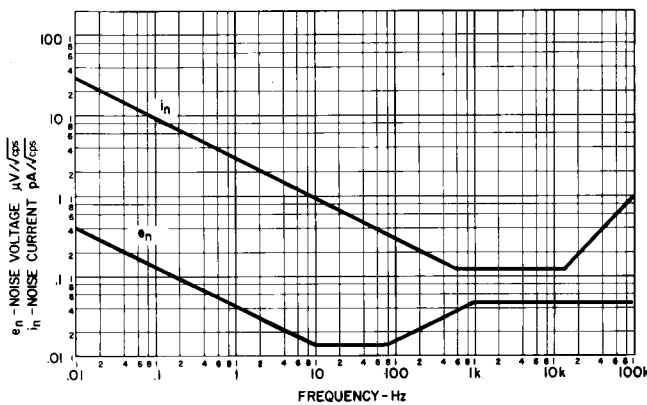

Figure 13. Voltage and Current Noise per Root cps Bandwidth for Model 183, a low-noise bipolar type

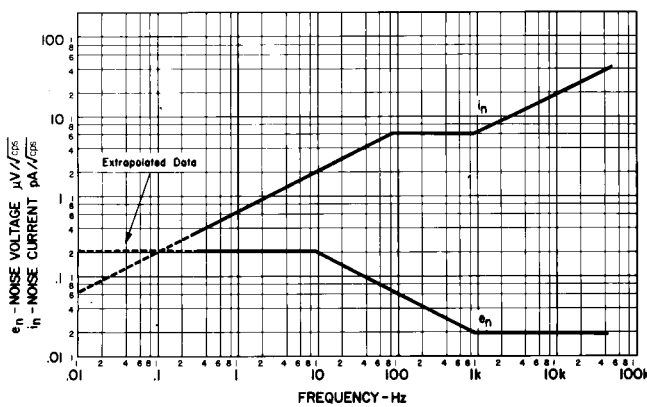

Figure 14. Voltage and Current Noise per Root cps Bandwidth for Model 230, a chopper-stabilized type (for discussion of chopper spike noise, see technical bulletin Model 230)

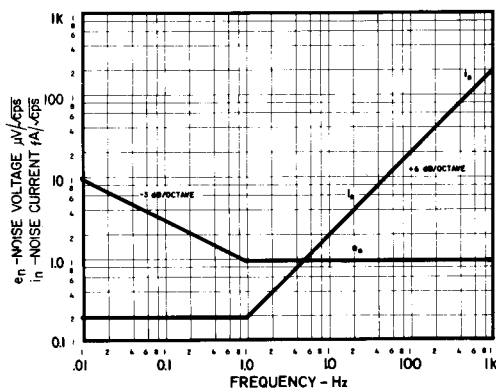

Figure 15. Voltage and Current Noise per Root cps Bandwidth for Model 310, a low-noise parametric electrometer type

APPENDIX II

DISCUSSION OF AMPLIFIER NOISE CURVES

Model 183. The region from DC to 10Hz is the voltage noise flicker region, with the characteristic -3dB/octave slope. The "cornering frequency", at which the characteristic changes to white noise, (very close to theoretical shot noise) is often considered by designers of operational amplifiers as an inverse figure-of-merit for noise evaluation of transistors. The 10Hz cornering frequency of Model 183's voltage noise is close to an order of magnitude lower than that of most bipolar-input operational amplifiers.

Voltage noise above 10Hz is caused by the drop of emitter shot noise current across the emitter resistance. The rise at 80Hz is due to shot noise effects in the second stage. In amplifiers with either a less conservative rolloff or with high gain-bandwidths, this rise may not occur before 1MHz.

The current noise spectral density curve is typical of that for low-noise bipolar-input operational amplifiers. The flicker region, with its -3dB/octave slope, is apparent. The level section at frequencies above the flicker region is shot noise caused by the base circuit bias current. The 6dB/octave rise in current noise above the shot region is due to voltage noise divided by the reactance of the irreducible-minimum amplifier input capacitance. (Note: this effect is especially pronounced in many amplifiers using capacitive feed-forward to obtain increased bandwidth). Typically, this increase of high-frequency current noise is seldom troublesome, because those applications in which large feedback resistors are employed often have at least a few pF of feedback capacitance, which will bury the effect.

Model 144. FET operational amplifiers allow users to obtain improved noise performance at high impedances. The low-cost Model 144 demonstrates the typical noise performance available in FET operational amplifiers.

Voltage noise: The entire spectrum, up to 10kHz, is dominated by flicker effects. Below 100Hz, the spectral density increases at less than 3dB/octave . Field-effect transistors have Johnson noise, rather than shot noise, at high frequencies, because their channels are resistive; however, it is so low as to be unobserved in typical operational amplifier designs, being dominated by shot noise from the bipolar transistors in following stages.

Current noise reaches its theoretical shot noise value of approximately $5.7 \times 10^{-4} \sqrt{I_{\text{bias}} \text{ pA} / \sqrt{\text{cps}}}$ between 1 Hz and 100Hz.

Well below 1Hz, flicker noise becomes dominant. Above 1kHz, voltage noise and input capacitance combine to provide the rising spectral density characteristic. Because of additional capacitance in the measuring equipment, the noise shown in this plot is likely to be greater than actually exists (and hence conservative for design purposes.)

NOTE TO THE READER:

Care must be taken when calculations are made with typical data, because deviations from "typical" will occur. In flicker-

dominated amplifiers, such as FET's, 15% or so of units tested will typically have as much as 2.5 times "typical" noise. However, the shot noise region will be uniform, with spreads of only $\pm 20\%$. For bipolar amplifiers, the spreads in the flicker regions will be of the order of 2:1, but only about $\pm 20\%$ elsewhere. Some amplifiers, such as 183, in which well-screened devices are used, will show only $\pm 20\%$ voltage noise variations, even in the flicker region. Parametric types, such as the 310 and 311, are flicker-free, and exhibit only $\pm 20\%$ variations over the entire spectrum.

APPENDIX III

A MISCELLANY OF PRACTICAL CONSIDERATIONS

The amplifier data provided have been obtained using ± 15 volt supplies. In general, flicker noise should increase or decrease somewhat as supply voltage increases or decreases.

The data for the curves was obtained at room temperature. In general, noise will not change appreciably with temperature, except for FET amplifiers. Because shot noise is proportional to the square root of the gate leakage current, FET current noise outside the flicker region at low frequencies tends to double for every 20° increase in temperature.

Because choice of amplifier type can result in as much as 6 orders of magnitude variation in noise, it is evident that the proper operational amplifier must be chosen for the application at hand. This is obvious if noise is inherently a factor in the design, but it is also essential to keep it from becoming an important limitation on performance in applications that appear less critical at first blush.

In general, FET amplifiers offer much lower low frequency noise in circuits using source impedances of 1 megohm and above. At very low frequencies, varactor bridge amplifiers offer even better (and more consistent) performance at high source impedances. Bipolar operational amplifiers (especially the 120, 183, 180) give excellent noise performance in low frequency, low source impedance applications. At high frequencies, the lowest noise will generally be obtained from amplifiers having the highest unity-gain crossover frequencies. (120, 220, and 121.)

NEW PRODUCT

LOW COST/GENERAL PURPOSE—\$11

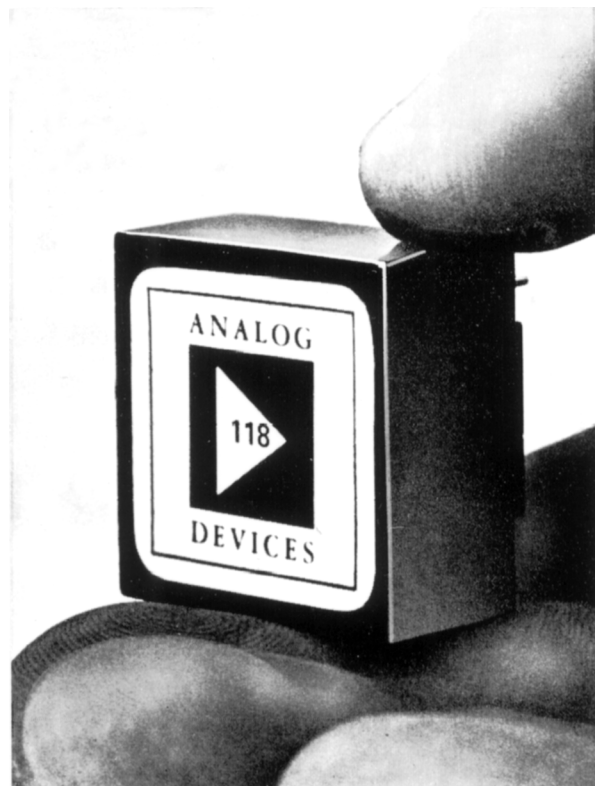

SPECIFICATIONS	118A/K
Open Loop Gain, min	2.5×10^5
Rated Output, min	$\pm 10V @ 5mA$
Full Power Resp. min	100kHz
Slew Rate, min	$6V / \mu sec$
Voltage Drift, max	$\pm 20 / 5 \mu V / ^\circ C$
Bias Current, max	$\pm .6 / .5 nA / ^\circ C$
Price (1-9)	\$11/\$21
(10-24)	\$10.50/\$19

Maximized user value really shows up in this new low cost series. The Model 118 offers performance that was simply unheard of just a few months ago. With every spec "one up" from I.C. types, the 118 is the best value available for literally hundreds of general purpose applications. Not even the spec table tells the whole story . . . A dual input transistor stage, usually found in much higher priced amplifiers, means immunity from "thermal gradient" errors and low noise. Other important advantages are high open loop gain, fast slew rate and low bias current. Models with 20 volt output swing and 20mA output currents are also available under \$25.

BIBLIOGRAPHY ON NOISE

Practical Handling of External Noise Sources

1. "Noise Reduction on Interconnect Lines"
E.L. Steward – *Simulation Journal* 1965 - Sept. pp. 149-155.
2. "Eliminating Pickup Noise in Test Equipment (Pt. I & II)"
George Golick – *Electronic Design* 1962 - April
3. "Stop Noise Problems Before They Start"
Thomas E. Skopal – *Electronic Design* 1969 - January 4th
4. "Help Stamp Out EMI!"
Robert B. Cowdell – *EDN* 1966 - November 23rd
5. "Design Noise Out of Spacecraft Payloads:"
Joseph C. Thornwall – *Electronic Design* 1968 - April 1. pp. 64-68.

Treatment of Noise in Amplifiers

6. Amplifier Handbook
Richard F. Shea – McGraw Hill, 1966, Chapter 7.
7. "Noise in Transistor Amplifier Circuits"
Bob Crawford – *Electro Technology* 1962 - November. pp. 63-70.

General Theory of Noise

8. Electrical Noise
W.R. Bennett - McGraw Hill, 1960
9. Principles of Noise
J.J. Freeman – John Wiley & Sons, Inc., 1958
10. Noise
A. Van der Ziel – Prentice-Hall, Inc., 1954
11. Noise in Electrical Circuits
F.N.H. Robinson – Oxford University Press, 1962

For those who are interested in pursuing further:

"Bibliography on Interference in Low Level Circuits", by Committee on Interference in Low Level Circuitry, *IEEE Transactions on Industrial Electronics and Control Instrumentation*, September, 1964.